

Investigation of the static reactions of a ship's shaft line with consideration of radial runout

Assoc. Prof. Christo Pirovsky

This article deals with the study of static reactions in the support bearings of the ship's shaft line, taking into account the influence of radial runout caused by residual deformations of the shafts.

The main goal is to establish how geometric deviations occurring during operation or after repair activities affect the distribution of reactions on the supports and the stressed state of the shaft line.

For the purposes of the study, a numerical model of the shaft line was developed using the finite element method. Parametric calculations were performed at different values of radial runout, and the resulting changes in loads and deformations were analyzed.

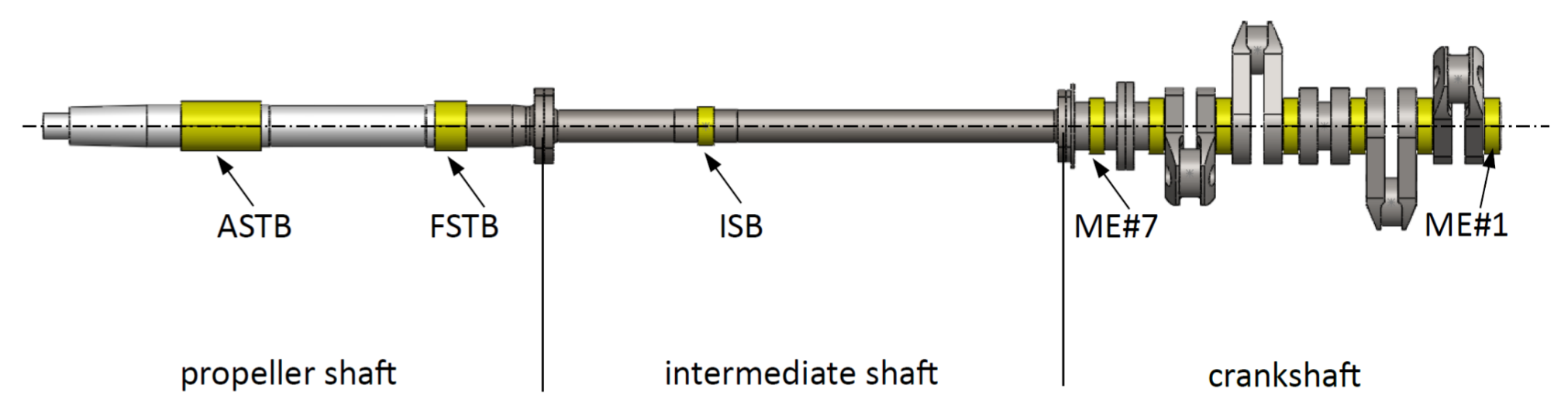
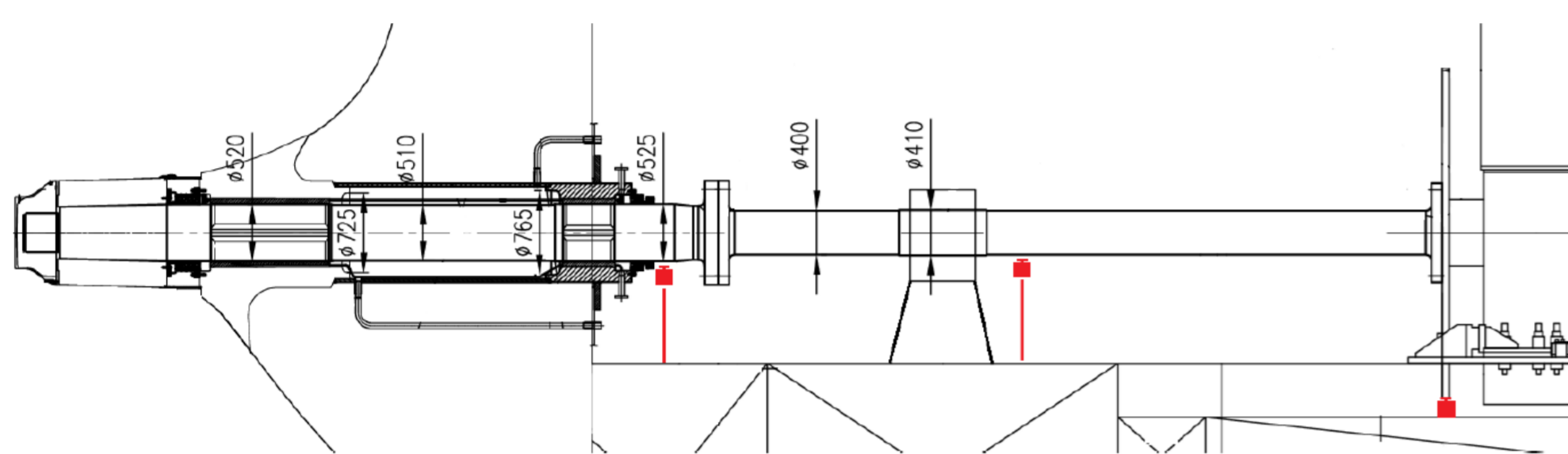

The residual deformation is given as a smoothly varying radial deflection along the length of the intermediate shaft with a maximum value in the mid-section of the intermediate shaft.

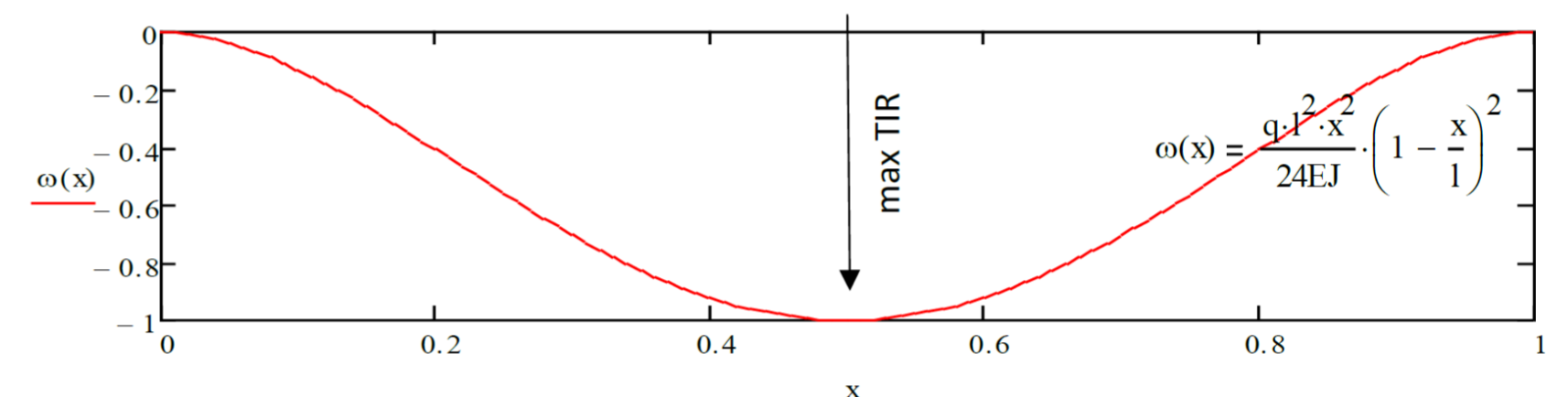

As a result of the numerical FEM study, polar diagrams of the calculated static reactions (N) were obtained for each bearing on the shaft line in accordance with the angle of rotation of the crankshaft.

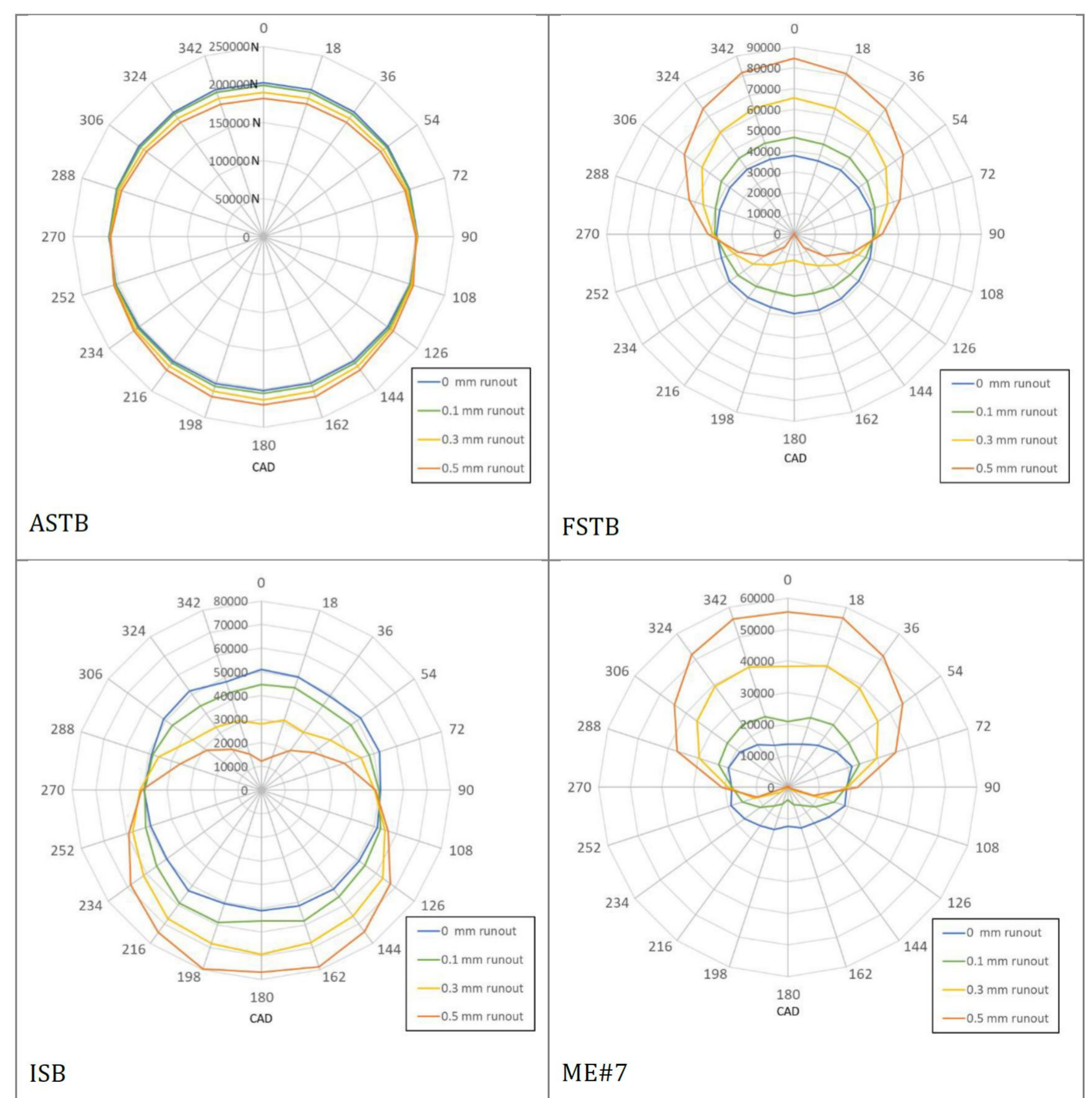

Deviations in the bearing load depending on the magnitude of the residual deformation:



The numerical study using a three-dimensional FEM model shows that the residual deformations of ship shafts have a significant impact on the static reactions of the bearings.

Comparison with measurements from a real ship confirms that the observed large variations in the reactions are due to residual deformations, which makes it impossible to directly compare the measured values with the manufacturer's design data.